

ProTalk[®] LINK

Operating Manual Hardware

June 2019
Rev. 4.02

***BE* BARNETT ENGINEERING LTD.**

#200, 550 – 71st Avenue SE
Calgary, Alberta, Canada
T2H 0S6

Phone: (403) 255-9544
Fax: (403) 259-2343
www.barnettprotalk.com
E-mail: sales@barnettprotalk.com

TABLE OF CONTENTS

1. INTRODUCTION.....	1
2. INSTALLATION OVERVIEW.....	2
3. M1 INSTALLATION	6
4. A1 INSTALLATION.....	10
5. D1 INSTALLATION.....	13
6. P1 INSTALLATION	16
7. P2 INSTALLATION	21
8. T1 INSTALLATION	24
9. W1 INSTALLATION.....	28
10. W2 INSTALLATION.....	32
11. W3 INSTALLATION.....	36
12. W4 INSTALLATION.....	40
13. SPECIFICATIONS	44
14. HANDSET PROGRAMMING.....	64
15. WARRANTY STATEMENT	80
16. NOTICES.....	81

1. INTRODUCTION

The ProTalk Link modular alarm reporting system provides a flexible, effective solution to a wide variety of alarm monitoring situations at an unattended site. When an alarm condition occurs, such as building intrusion, power failure or equipment upset, the Link automatically places calls to inform people of the situation. These calls can be voice, email, SMS text or paging depending on the selected communication module. In the case of unanswered voice calls, the Link will continue to dial through the list of programmed numbers until it successfully reaches someone and is able to report the alarm.

An effective match between the alarm sources and the communication channels is easily done with plug-together modules. Each system consists of one Main module and at least one communication module. The choice of communication module is determined by the type of channel (or channels) you want to call out on and more than one communication module can be used in cases where redundancy is required. For low density alarm counts, the input/output capabilities of a communication module will be adequate. When the alarm count exceeds this capacity, one or more of the discrete I/O modules can be used. The PLC module can be used to communicate directly with a controller without using individually wired connections.

The ProTalk Link modules plug together to build up the system you want. Every system has one Main module and one or more expander modules. Throughout the manual, the modules are referred to in short form in this way: the B1285-M1 is an M1 module, the B1285-W1 is a W1 and so on.

This manual contains information to help you install and configure a ProTalk Link alarm reporting system. For basic applications, a Link system can be programmed with a safety approved Touch-Tone telephone by following the steps in this manual. For more advanced configurations, it will be necessary to use the PC programming application supplied with the unit. For details on programming with a PC, refer to the help files contained in the LINK.EXE PC application.

The first sections in this manual show you how to install the Link system hardware followed by a description of the telset programming method.

2. INSTALLATION OVERVIEW

The Link should be installed in a clean, dry indoor location suitable for electronic equipment.

Caution: Power, telephone lines and antenna cables should be connected only after the installation is complete.

Each system starts with a Main B1285-M1 module. The appropriate expander modules are then added to provide the required communications and I/O functionality. The first expander module is plugged into the Main module, then the next expander into the first expander and so on. The ProTalk Link System accepts a maximum of 16 modules (B1285-M1 module + a maximum of 15 expander modules).

Connection of the plug-together modules is shown in Figure 1. Mounting ears are provided for back panel installation. A desktop arrangement can be also used where the modules are stacked on top of each other. Each added module is secured to the previous module with joiner plates attached to the sides.

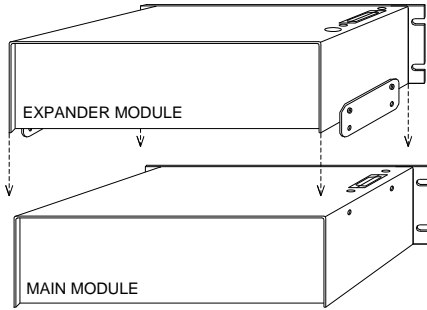

Step 1: Position the expander module over the main module so the connectors line up then slide the parts together.

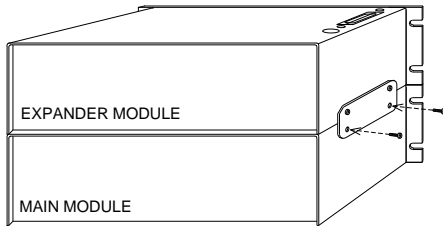

Step 2: Fasten the two modules together with bolts through the joiner plates on each side.

Figure 1 Module Connection

Every expander requires a unique address set by the rotary switch located on the top cover shown in Figure 2. Although the address setting and the physical location of the expander in the assembly are not related, the recommended method is to number the expanders from 1 upwards as they are connected together. If there is a PLC module, it is recommended that any I/O or communications modules be addressed, starting from 1, then the PLC module given the next available address.

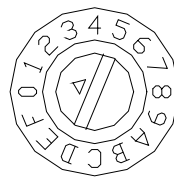

Figure 2 Address Switch

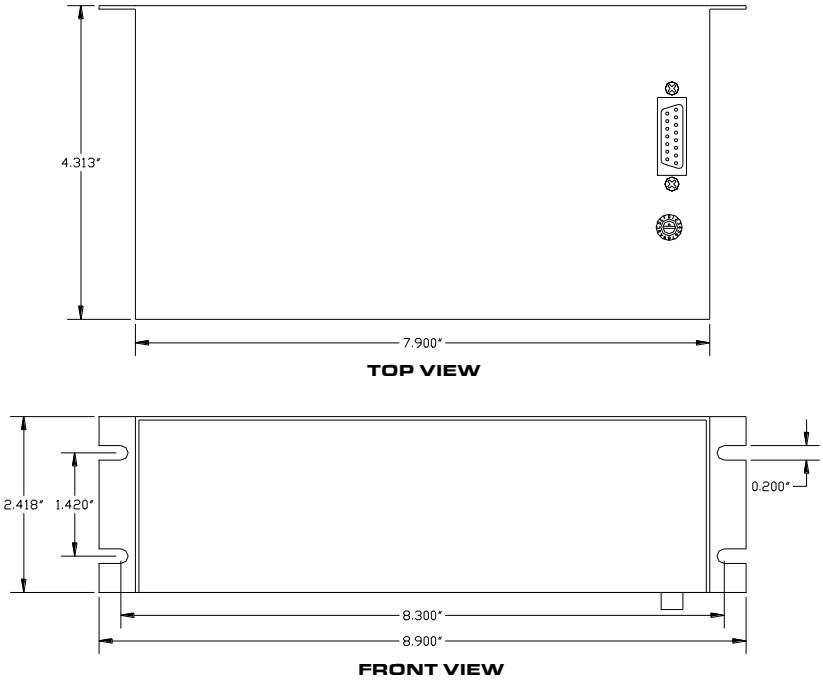

Figure 3 Module Dimensions

Figure 3 shows the dimensions for both Main and expander modules. The Main module does not have the connector on the bottom nor an address switch; it is always address 0.

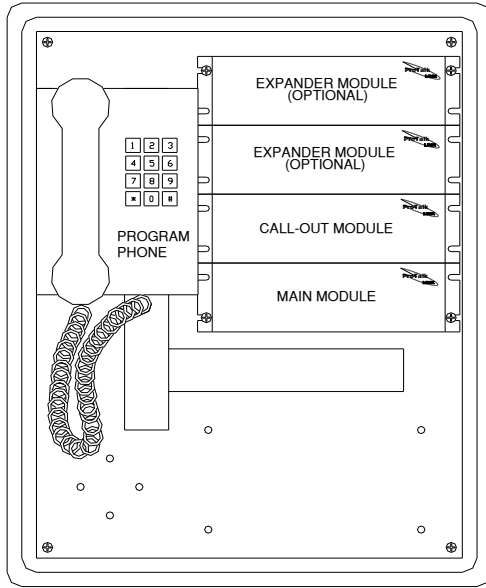

Figure 4 ProTalk LINK in a NEMA enclosure

Figure 4 shows the ProTalk LINK, with three expanders, when it is mounted in a NEMA enclosure.

3. M1 INSTALLATION

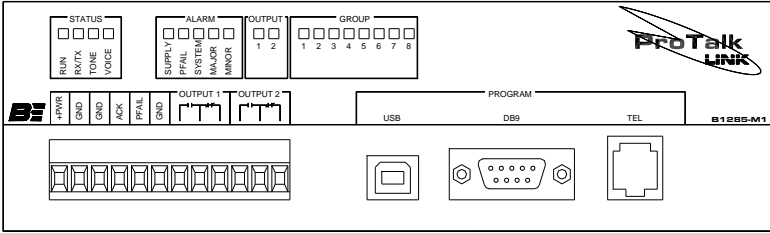

Figure 5 M1 Module Front Panel

The M1 module controls all of the alarm reporting operations. An exception exists following a system failure when the communication modules change to autonomous mode and perform a basic callout (to announce the system failure). Communications and power to the expanders is taken through the mating connectors on the top and bottom of the modules.

Connectors - Power and Signal

Refer to Figure 7 for details of the connector pinouts and Figure 8 for details of the serial cable required for programming.

Power

Input voltage is connected to the M1 module only. Attach the ground lead of the external supply to the GND terminal and the positive lead to the +PWR terminal. Note that the chassis of the Link system is connected to ground. The Link System requires a power supply voltage of 10-30 VDC, 2.8A Max. The power supply used should be a safety approved Class 2 power supply source, current limited using a 3A in-line slow-blow fuse.

Total system power will depend on the number and type of modules that are in operation. Each module draws a maximum of 150 mA with all indicators on. The W1, W2, W3 and W4 modules are exceptions drawing 300 mA, 650 mA, 350 mA and 350 mA respectively when transmitting at maximum power and all indicators on.

Input power is monitored as an analog value by the M1 module and can be programmed as an alarm.

Local Acknowledge Input

If an external acknowledge pushbutton is to be used with the system, it should be connected between the ACK terminal and ground; do not apply voltage to the ACK input. The pushbutton must be a normally open type. The circuit for ACK and PFAL is shown in Figure 6.

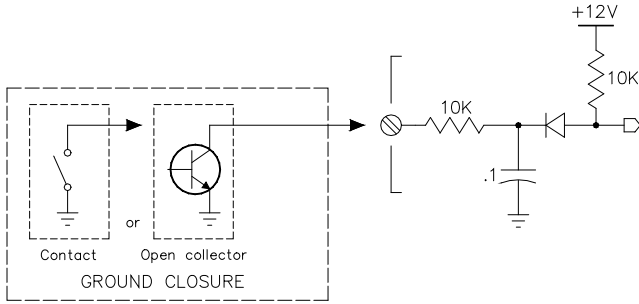

Figure 6 ACK and PFAIL Input Circuit

Power Fail Input

If a power failure status is available from the external power supply, it can be connected between the PFAIL input and ground and then used to generate an alarm. The power fail signal must be a relay contact or open collector; do not apply voltage to the PFAIL input. In the programming for this alarm, the normal state can be set for either open or ground.

Output Relays

If external equipment is to be notified of system status conditions, the output relays can be used. Each of the two relays can be programmed to indicate one of these status conditions:

- New alarm exists
- Any alarm exists
- Acknowledge received
- Error condition

Any of the 8 groups can be included in the status for each type.

Connectors - Programming

DB9

This DTE RS232 programming port is used to:

- Transfer configuration data containing the programmed operating parameters
- Transfer voice data with the user programmed messages
- Transfer vocabulary data containing the 'canned' voices used by the system
- Upgrade files for flashing new code into the modules
- Monitor current system conditions

USB

The USB port performs the same function as the DB9 port. When a cable is plugged into this port, the DB9 port is not operational.

TEL

The TEL port accepts a safety approved Touch-Tone telephone and is used to record the voice messages, interrogate points, acknowledge alarms and enter control codes. Limited programming functionality is available through the telset.

Do not plug a telephone line into this port.

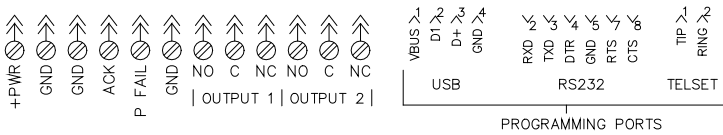

Figure 7 M1 Module Connections

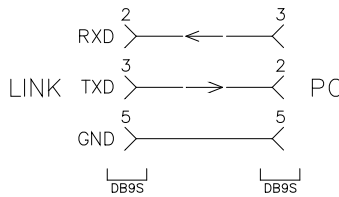

Figure 8 M1 DB9 to PC Programming Cable

Indicators

The indicators are grouped into 4 sections:

1) Status

Run

- Flashing Red during startup while the flash memory is being checked and the system initialized.
- Red when in program mode, either by the local telset or a connected PC
- Green during normal operations
- Flashing green when in low power mode

RX/TX

- Green when a message is sent to an expander on the internal communications bus.
- Red if the message has to be resent due to a communications error
- Green/Red flash during PC communications

Tone

- Flashes Green when a DTMF tone has been received.
- Off otherwise

Voice

- Green when speaking
- Red when recording
- Off when idle

2) Alarm

Supply, Power Fail, System, Major, Minor

- Flashing Red with an unacknowledged alarm
- Solid Red with an acknowledged alarm
- Off when idle

3) Output

Two, one for each output

- Red when active
- Off otherwise

4) Group

Eight, one for each group

- Off if the group is disabled
- Green if the group is enabled and there are no alarms in the group
- Flashing Red if the group is enabled and there is an alarm in the group
- Flashing Yellow if the alarms in the group are in the process of being reported
- Solid Red when the alarms have been acknowledged

4. A1 INSTALLATION

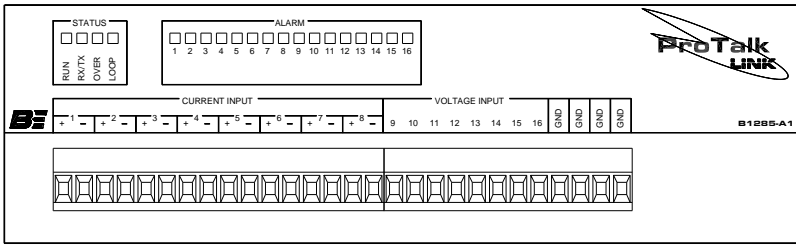

Figure 9 A1 Module Front Panel

This module provides a total of 16 analog inputs; 8 using 4-20 mA current loop signals and 8 using single ended voltage inputs. The voltage inputs can be configured for +5, +10 or +30 VDC full scale. Each input can be independently configured for alarm reporting. The front panel shown in Figure 9 has all of the external connections as well as status indicators displaying the module state.

Connections

Front panel terminal block connections are shown in Figure 10.

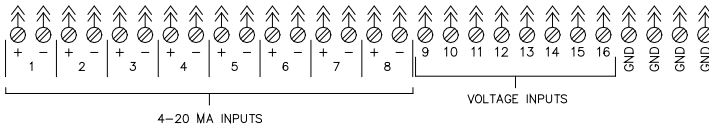

Figure 10 Front Panel - Connections

Current Loop Inputs

The first 8 inputs on the module are the current inputs. Each input has two terminals for placing it into the current loop. Current flow must be such that the current source enters the + terminal and exits from the - terminal. The input can be either at the top of the loop with the + terminal connected to the loop excitation voltage, or it can be at the bottom of the loop with the - terminal connected to the return of the loop excitation supply. Internal impedance is 100 ohms so the drop across the input is 2 VDC at full scale when 20 mA is flowing. The maximum common mode voltage that can be placed on the inputs is +35 VDC. If the loop is not connected or the current flow drops below 4 mA, an open loop alarm can be generated. This alarm can be selected as either major or minor and is reported for the module and not for a specific input. A current input circuit is shown in Figure 11.

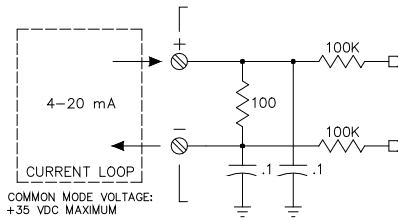

Figure 11 A1 Current Input Circuit

Voltage Inputs

Voltage inputs are configured by the programming application to match the full scale range of the analog input voltage; +5, +10 or +30 VDC. If a voltage greater than the programmed maximum is applied, the result will be a full scale reading and an over voltage error can be generated. This alarm can be selected as either major or minor and is reported for the module and not for a specific input. A voltage input can withstand a constant voltage of up to +35 VDC regardless of the programmed range setting. The circuit for a voltage input is shown in Figure 12.

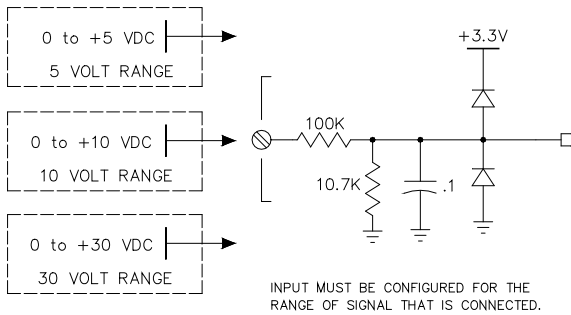

Figure 12 A1 Voltage Input Circuit

Indicators

The indicators are grouped into 2 sections:

1) Status

Run

- Flashing Red during startup before a database is received from the main module
- Green during normal operations

RX/TX

- Normal operations
- Green on receipt of valid message from the main module
- Yellow if the message from the main module has a checksum error. This indicator times out after 400 msec

Over

- Flashing Red when a voltage input is over range
- Off otherwise

Loop

- Flashing Red when a current loop input is open
- Off otherwise

2) Alarm

Sixteen, one for each input

- Flashing Red when the associated input is in the alarm state
- Red when the associated input is in the alarm state and has been acknowledged
- Off when idle

5. D1 INSTALLATION

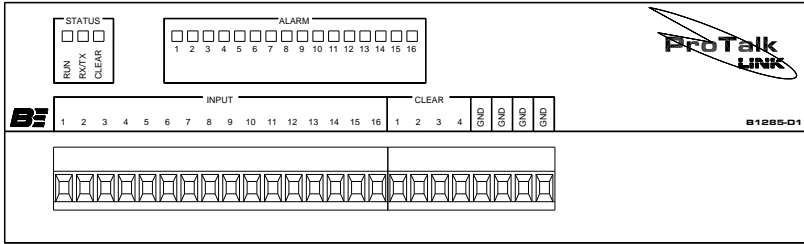

Figure 13 D1 Module Front Panel

The D1 module provides a total of 16 digital inputs that can be independently programmed to operate as one of five different types:

- Standard digital
- Watchdog timer
- Interval timer
- Totalizer
- Accumulator

Each input can be programmed to accept three different signal level formats:

- Open / Ground
- Open / +Voltage between +5 and +30 VDC
- Ground /+Voltage between +5 and +30 VDC

Clear inputs are used to reset the value of a totalizer or accumulator and are always associated with a specific digital input. Clear inputs 1 through 4 work with digital inputs 1 through 4 respectively; totalizers or accumulators derived from other inputs can be reset using DTMF only. The signal format for each clear input is the same as its associated digital input. If the format is configured for Ground/+Voltage, the module can be programmed to generate an alarm when the input is open instead of in either of the expected states. This alarm can be selected as either major or minor and is reported for the module and not for a specific input.

Connections

Connection points for the inputs are shown in Figure 14.

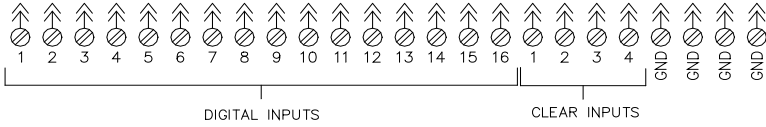

Figure 14 D1 Front Panel - Connections

The circuit for the inputs is shown in Figure 15.

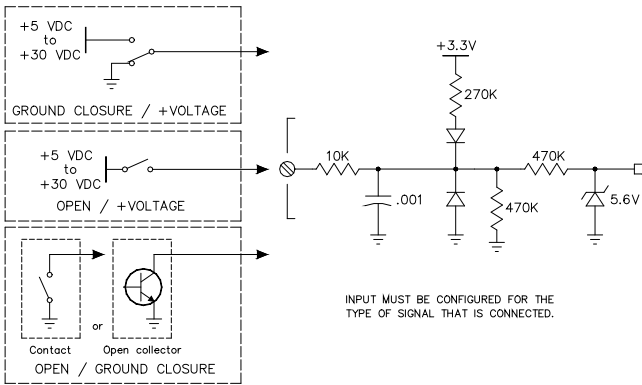

Figure 15 D1 Input Circuit

Indicators

The indicators are grouped into 2 sections:

1) Status

Run

- Flashing Red during startup before a database is received from the main module
- Green during normal operations

RX/TX

- Normal operations
- Green on receipt of valid message from the main module
- Yellow if the message from the main module has a checksum error. This indicator times out after 400 msec

Clear

- Green when any clear input is active
- Off when all clear inputs are idle

2) Alarm

Sixteen, one for each input

- Flashing Red when the associated input is in the alarm state
- Yellow when there is an error with an input connection
- Red when the associated input is in the alarm state and has been acknowledged
- Green when active as an Interval or Accumulator
- Off when idle

6. P1 INSTALLATION

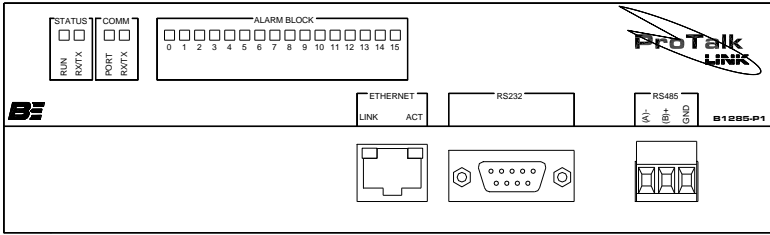

Figure 16 P1 Module - Front Panel

The P1 module provides connectivity between the Link system and a PLC. Communications between the P1 module and the PLC can be done using one of the available ports: the RS232 serial port, the RS485 serial port or, for Modbus systems, the Ethernet port. Only one of the three ports can be assigned for PLC communications at a time. The Ethernet port is available for monitoring the status of the Link system regardless of which port is selected for PLC communications.

Protocols used by the module are:

- Modbus slave
- Modbus master
- Modbus TCP/IP slave
- Modbus TCP/IP master
- Allen-Bradley DF1 Point-to-Point PLC5 master
- Allen-Bradley DF1 Point-to-Point SLC-500 master.

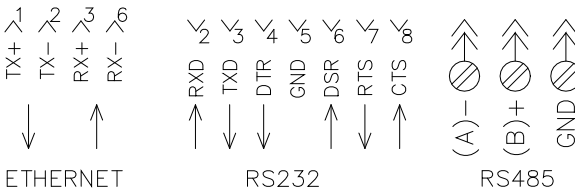

Figure 17 P1 Module - Connectors

Connectors

RS232

This DTE RS232 serial port connected to the communications port of the PLC. Either this port or the RS485 port is selected in the configuration; both do not operate at the same time.

RS485

The RS485 port performs the same function as the RS232 port. Either this port or the RS232 port is selected in the configuration; both do not operate at the same time.

ETHERNET

Ethernet connectivity with the Link system is available through this port. TCP/IP communications with the PLC and system monitoring are done here.

Indicators

The indicators are grouped into 4 sections:

1) Status

Run

- Flashing Red during startup before a database is received from the main module
- Green during normal operations

RX/TX

- Normal operations
- Green on receipt of valid message from the main module
- Yellow if the message from the main module has a checksum error. This indicator times out after 400 msec

2) Comm

Port

- Green if the Ethernet port has been selected
- Yellow if the RS232 port has been selected
- Red if the RS485 port has been selected

RX/TX (RS232 and RS485 only)

- Solid Green during initial message poll
- Solid Red during a message retry

3) Alarm Block

Sixteen, one for each of the first 16 blocks of the system

- Flashing Red when any point in a block is in the alarm state
- Solid Red when all alarms in a block are acknowledged
- Off when all points are idle

4) Ethernet Connector

Link

- Illuminated when the cable is connected

Active

- Illuminated when packets are being transferred

Communications Error Codes

Modbus Error Codes	
00	success
01	illegal function
02	illegal data address
03	illegal data value
04	failure in associated device
05	acknowledge long command
06	"busy, rejected message"
07	NAK - negative acknowledge
08	memory parity error
FD	not enough characters
FE	CRC error
FF	no response

Data Highway and DH-485 Error Codes	
00	success
x2	cannot guarantee delivery, link layer
x3	duplicate token holder detected
x4	local port is disconnected
x5	application layer timed out waiting for a response
x6	duplicate node detected
x7	station is off-line
x8	hardware fault
1x	illegal command or format
2x	host has a problem and will not communicate
3x	remote node host is missing, disconnected, or shut down
4x	host could not complete function due to hardware fault
5x	addressing problem or memory protected rungs
6x	function disallowed due to command protection selection

7x	processor is in program mode
8x	compatibility mode file missing or communication zone problem
9x	remote node cannot buffer command
Bx	remote node problem due to download
Cx	cannot execute command due to active IPBs
D1	a field has an illegal value
D2	less levels specified in address than minimum for any address
D3	more levels specified in address than system supports
D4	symbol not found
D5	symbol is of improper format
D6	address doesn't point to something
D7	file wrong size
D8	cannot complete request, situation has changed since the start of the command
D9	data or file is too large
DA	transaction size plus word address is too large
DB	access denied, improper privilege
DC	condition cannot be generated - resource is not available
DD	condition already exists - resource is already available
DE	command cannot be executed
DF	histogram overflow
E0	no access
E1	illegal data type
E2	invalid parameter or invalid data
E3	address reference exists to deleted area
E4	command execution failure for unknown reason
E5	data conversion error
E6	scanner not able to communicate with 1771 rack adapter
E7	adapter cannot communicate with module
E8	1771 module response was not valid
E9	duplicated label
EA	file is open; another node owns it
EB	another node is the program owner

FD	not enough characters
FE	CRC error
FF	no response

7. P2 INSTALLATION

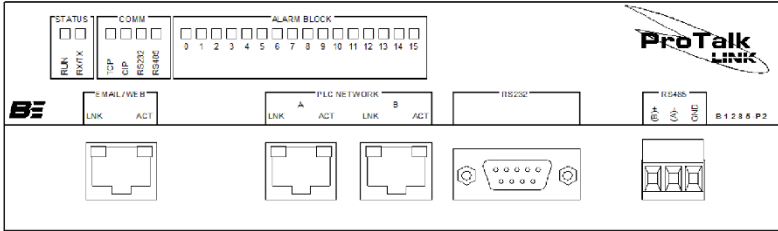

Figure 188 P2 Module - Front Panel

The P2 module provides connectivity between the Link system and a PLC. Communications between the P2 module and the PLC can be done using any the available ports: the RS232 serial port, the RS485 serial port or the PLC Network Ethernet port. Additionally, the Web/Email Ethernet port is available for monitoring the status of the Link system or transmitting emails.

Protocols used by the module for PLC communications are:

- Modbus RTU slave
- Modbus RTU master
- Modbus TCP slave
- Modbus TCP master
- Allen-Bradley DF1 Point-to-Point PLC5 master
- Allen-Bradley DF1 Point-to-Point SLC-500 master.
- EtherNet/IP Adapter

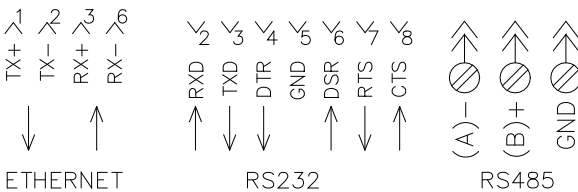

Figure 19 P2 Module - Connectors

Connectors

WEB/EMAIL ETHERNET

This connector is used for connecting the Link system to a network that has access outside the local environment. A web server is provided

through this port for remote monitoring and emails can be transmitted through this port to a remote server.

PLC ETHERNET

These two connectors are used for local PLC network connection. Both connectors are bridged internally so the network can be wired through either connector or wired in a daisy-chain configuration in one and out the other. Modbus TCP and EtherNet/IP communications with the PLCs are connected here. Multiple protocols can run at the same time.

RS232

The DTE RS232 serial port connects to the communications port of the PLC. The protocol used through this port is selected in the configuration; only one protocol can be assigned to this port.

RS485

The RS485 port performs the same function as the RS232 port. The protocol used through this port is selected in the configuration; only one protocol can be assigned to this port.

Indicators

The indicators are grouped into 4 sections:

1) Status

Run

- Flashing Red during startup or when a database is received from the main module
- Green during normal operations

RX/TX

- Normal operations
- Green on receipt of valid message from the main module
- Yellow if the message from the main module has a checksum error. This indicator times out after 400 msec

2) Comm

TCP

Modbus TCP Master

- Solid Red - no response
- Solid Green - valid response
- Solid Yellow – invalid response

Modbus TCP Slave

- Solid Red - no message
- Solid Green - valid message
- Solid Yellow – invalid message

CIP

- Blink Green when an EtherNet/IP message is exchanged

RS232

Modbus RTU Master

- Solid Red – no response
- Solid Green – valid response
- Solid Yellow – invalid response

Modbus RTU Slave

- Solid Red – no response
- Solid Green – valid response
- Solid Yellow – invalid message

Modbus AB-DFI Master

- Solid Red – no response
- Solid Green – valid response
- Solid Yellow – invalid response

RS485

Modbus RTU Master

- Solid Red – no response
- Solid Green – valid response
- Solid Yellow – invalid response

Modbus RTU Slave

- Solid Red – no response
- Solid Green – valid response
- Solid Yellow – invalid message

Modbus AB-DFI Master

- Solid Red – no response
- Solid Green – valid response
- Solid Yellow – invalid response

3) Alarm Block

Sixteen, one for each of the first 16 blocks of the system

- Flashing Red when any point in a block is in the alarm state
- Solid Red when all alarms in a block are acknowledged
- Off when all points are idle

4) Ethernet Connectors (all)

Link

- Illuminated when the cable is connected

Act

- Illuminated when packets are being transferred

8. T1 INSTALLATION

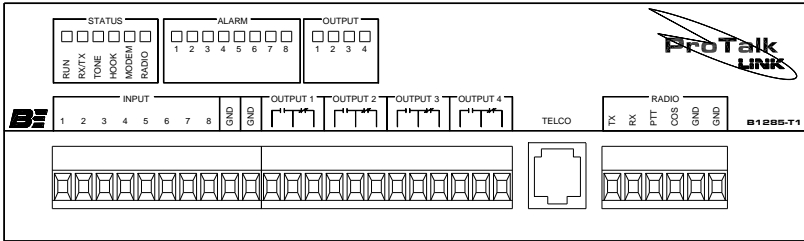

Figure 20 T1 Module Front Panel

The T1 module provides callout capability on a telephone line and/or a mobile radio port. The radio port can also be used to operate a public address system. In addition to communications functions, this module also has 8 digital inputs that can be independently programmed to operate as one of five different types:

- Standard digital
- Watchdog timer
- Interval timer
- Totalizer
- Accumulator

There are also 4 relay outputs that can be used for remote control; these relays are controlled by incoming DTMF codes.

Connectors

Refer to Figure 21 for details of the connector pinouts.

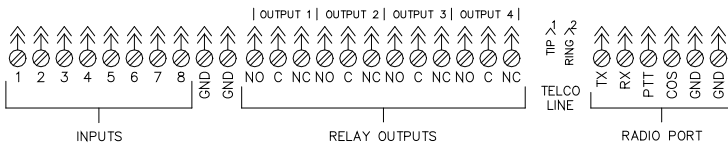

Figure 21 T1 Module Connections

Inputs

The eight digital inputs operate with a dry relay contact or open collector to ground as shown in Figure 22. In the open state the input is pulled high internally and in the ground state it is pulled to ground.

Relay Outputs

Each of the 4 relays can be configured during programming to provide remote control outputs that are operated by DTMF codes.

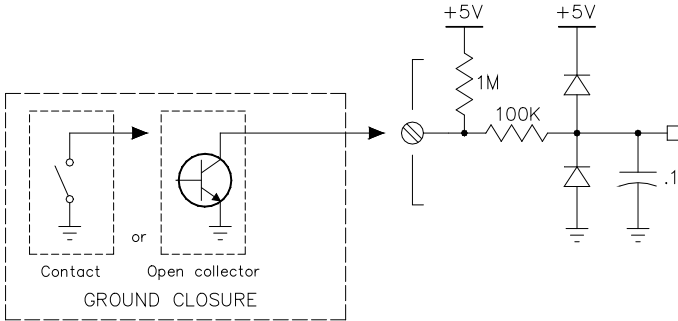

Figure 22 T1 Input Circuit

Telco RJ11

This is the port that connects to a conventional telephone line and is used by the T1 module to place calls and announce alarm messages. There is an on-board modem that provides the ability to answer incoming data calls if a DTMF modem code has first been entered. The T1 module can be called through this port by the Link configuration application, allowing configuration settings to be remotely changed using the PC. A limited amount of programming can also be done using a Touch-Tone set to call into the module.

Radio Port

Connection to a land mobile base station is through this port. The signals available are:

TX	Audio from the T1 module to the radio
RX	Audio from the radio to the T1 module
PTT	Ground closure from the T1 module to activate the radio transmitter
COS	Ground closure from the radio to indicate the radio channel is busy

A public address system can be connected to the module using just the TX and PTT lines.

Indicators

The indicators are grouped into 3 sections:

1) Status

Run

- Flashing Red during startup before a database is received from the main module
- Green during normal operations

RX/TX

- Green on receipt of valid message from the main module
- Yellow if the message from the main module has a checksum error. This indicator times out after 400 msec

Tone

- Green when a tone is being received
- Red when a tone is being transmitted
- Off when idle

Hook

- Red when ringing on an incoming call
- Green when off hook
- Off when idle

Modem

- Green when modem is waiting for a connection
- Yellow when connected
- Red when disconnected
- Off when idle

Radio

- Green when PTT is active
- Red when the channel is busy
- Off when idle

2) Alarm

Eight, one for each input

- Flashing Red when the associated input is in the alarm state
- Red when the associated input is in the alarm state and has been acknowledged
- Green when active as an Interval or Accumulator
- Off when idle

3) Output

Four, one for each output

- Red when the relay is in the on state
- Yellow if the relay has failed
- Off otherwise

9. W1 INSTALLATION

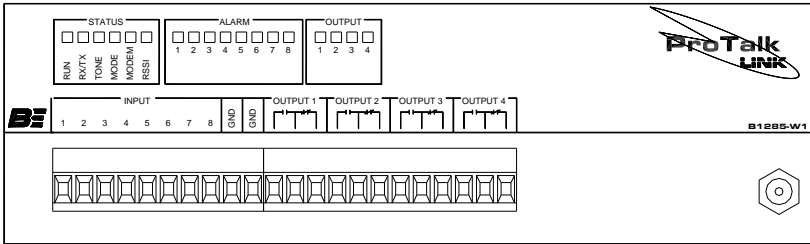

Figure 23 W1 Module Front Panel

The W1 module provides wireless callout capability through an embedded GSM cell phone. In addition to communications functions, this module also has 8 digital inputs that can be independently programmed to operate as one of five different types:

- Standard digital
- Watchdog timer
- Interval timer
- Totalizer
- Accumulator

There are also 4 relay outputs that can be used for remote control; these relays are controlled by incoming DTMF codes.

For more advanced callout requirements, the module can be configured to send email messages containing the alarm information. A limited amount of programming can also be done using a Touch-Tone set locally or by calling into the module.

This module can also be used to transfer a database to the ProTalk Link if the internal cell phone is registered with a data plan through the wireless carrier. See the LINK.EXE pc application’s Help section for details on using this feature.

Connectors

Refer to Figure 24 below for details of the connector pinouts.

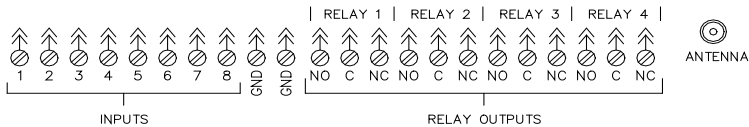

Figure 24 W1 Module Connections

Inputs

The eight digital inputs operate with a dry relay contact or open collector to ground as shown in Figure 25. In the open state the input is pulled high internally and in the ground state it is pulled to ground.

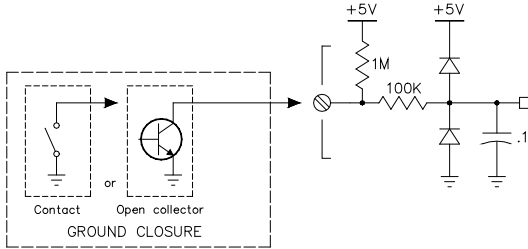

Figure 25 W1 Input Circuit

Relay Outputs

Each of the 4 relays can be configured during programming to provide remote control outputs that are operated by DTMF codes.

Indoor Antenna

Indoor Antenna Installation

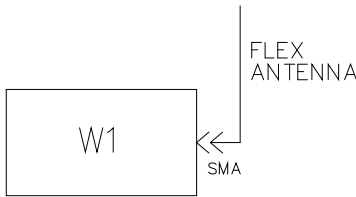

For the W1 Link module to successfully make cellular calls, there must be adequate signal strength at its antenna port. The flex antenna supplied with the module is suitable for installations where there is sufficient signal strength. This configuration is shown in Figure 26.

Figure 26 Indoor Antenna

Indicators

The indicators are grouped into 3 sections:

1) Status

Run

- Flashing Red during startup before a database is received from the main module
- Green during normal operations

RX/TX

- Green on receipt of valid message from the main module

- Yellow if the message from the main module has a checksum error. This indicator times out after 400 msec

Tone

- Green when a tone is being received
- Red when a tone is being transmitted
- Off when idle

Mode

- Green when connected to the home cellular network
- Yellow when connected to cellular network and roaming
- Red/Green flashing when ringing or call in progress
- Red when status is disconnected
- Off otherwise

Modem

- Green when modem is enabled
- Yellow when the modem has a data connection
- Red when disconnecting
- Off when disconnected

RSSI

- Flashing Red when RSSI is 0 (very poor)
- Red when RSSI is between 1 and 3 (poor)
- Yellow when RSSI is 4 or 5 (marginal)
- Green when RSSI is 6 or greater (good)
- Off for undetectable or unknown RSSI

2) Alarm

Eight, one for each input

- Flashing Red when the associated input is in the alarm state
- Red when the associated input is in the alarm state and has been acknowledged
- Green when active as an Interval or Accumulator
- Off when idle

3) Output

Four, one for each output

- Red when the relay is in the on state
- Yellow if the relay has failed
- Off otherwise

SIM Card Installation

The B1285-W1 utilizes an embedded GSM cell phone module to make calls. To operate on a wireless network, a valid SIM card (Subscriber Identity Module) must be obtained from your carrier and installed in this module. The SIM cardholder is located inside the cell phone module; it is necessary to remove the top from the B1285-W1 case in order to gain access to the cell phone module. *It is important to observe proper electrostatic grounding precautions and to disconnect power prior to performing this procedure.*

What you'll need:

- Phillips screwdriver
- Active SIM card

Installation Steps:

- Separate the W1 module from the connecting unit(s) by removing the screws from the connector plates on either side of the unit.
- Remove the four black screws holding the lid on.
- Remove the two silver screws on the top of the unit and separate the lid from the base. Note: there is an aluminum shim around the DB15 connector that is necessary for assembly. Don't lose it.
- Position the unit so the front is facing away from you.
- You will see a silver Modem Module on the circuit board. On the edge closest to you is where you will find the SIM card holder (Figure 27 below).
- To access the holder, use a fine point object to depress the yellow eject button.
- Remove the small black holder and place the SIM card in the holder taking note of the keyed pad.
- Return the holder with the SIM card to the space in the Modem Module.
- Ensure the aluminum shim is around the DB15 connector.
- Put the lid on and replace the silver screws on the top of the unit.
- Replace the four black screws that secure the lid.
- Reattach the W1 to the connecting units using the connector plates and remaining screws.

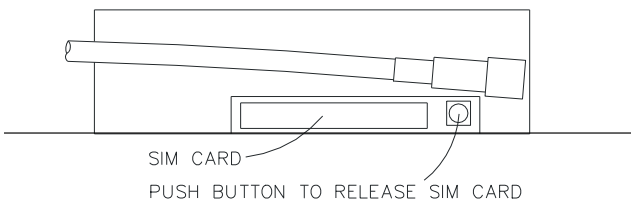

Figure 27 Rear View of Modem Module

10. W2 INSTALLATION

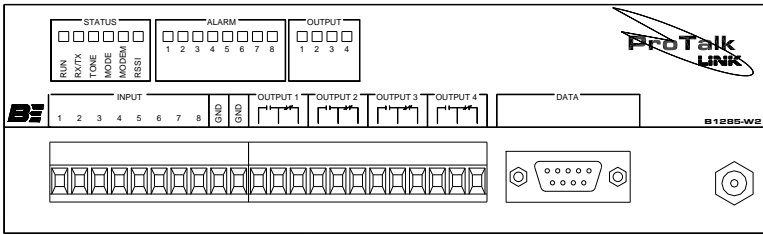

Figure 28 W2 Module Front Panel

The W2 module provides wireless callout capability through an embedded CDMA cell phone. In addition to communications functions, this module also has 8 digital inputs that can be independently programmed to operate as one of five different types:

- Standard digital
- Watchdog timer
- Interval timer
- Totalizer
- Accumulator

There are also 4 relay outputs that can be used for remote control; these relays are controlled by incoming DTMF codes.

A limited amount of programming can also be done using a safety approved Touch-Tone telephone locally or by calling into the module.

This module can be used to transfer a database to the ProTalk Link if the internal cell phone is registered with a data plan through the wireless carrier. It can also transfer data between the external DB9 connector and the cell phone’s modem. See the LINK.EXE PC application’s Help section for details on using these features.

Connectors

Refer to Figure 29 below for details of the connector pin outs.

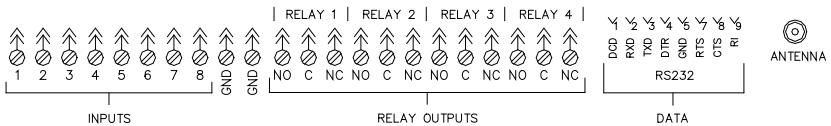

Figure 29 W2 Module Connections

Inputs

The eight digital inputs operate with a dry relay contact or open collector to ground as shown in Figure 30. In the open state the input is pulled high internally and in the ground state it is pulled to ground.

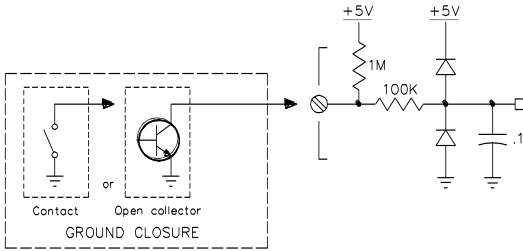

Figure 30 W2 Input Circuit

Relay Outputs

Each of the 4 relays can be configured during programming to provide remote control outputs that are operated by DTMF codes.

Antenna

Connection of the external antenna is at the SMA female coax connector.

Indoor Antenna Installation

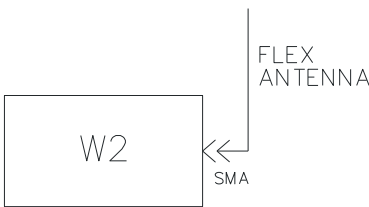

Figure 31 Indoor Antenna

For the W2 Link module to successfully make cellular calls, there must be adequate signal strength at its antenna port. The flex antenna supplied with the module is suitable for installations where there is sufficient signal strength. This configuration is shown in Figure 31.

Indicators

The indicators are grouped into 3 sections:

1) Status

Run

- Flashing Red during startup before a database is received from the main module
- Green during normal operations

RX/TX

- Green on receipt of valid message from the main module
- Yellow if the message from the main module has a checksum error. This indicator times out after 400 msec

Tone

- Green when a tone is being received
- Red when a tone is being transmitted
- Off when idle

Mode

- Green when connected to the home cellular network
- Yellow when connected to cellular network and roaming
- Red/Green flashing when ringing or call in progress
- Red when disconnected
- Off otherwise

Modem

- Green when the modem is enabled
- Yellow when the modem has a data connection
- Red when disconnecting
- Off when disconnected

RSSI

- Flashing Red when RSSI is 0 (very poor)
- Red when RSSI is between 1 and 3 (poor)
- Yellow when RSSI is 4 or 5 (marginal)
- Green when RSSI is 6 or greater (good)
- Off for undetectable or unknown RSSI

2) Alarm

Eight, one for each input

- Flashing Red when the associated input is in the alarm state
- Red when the associated input is in the alarm state and has been acknowledged
- Green when active as an Interval or Accumulator
- Off when idle

3) Output

Four, one for each output

- Red when the relay is in the on state
- Yellow if the relay has failed
- Off otherwise

CDMA Module Activation

The B1285-W2 utilizes an embedded CDMA cell phone module to make calls. To operate on a wireless network, a valid MIN (Mobile

Identification Number) and MDN (Mobile Directory Number) must be obtained from your carrier and programmed into the unit.

For programming instructions, refer to Wireless Module Programming in the Handset Programming section or to the ProTalk Link PC software and associated help files.

11. W3 INSTALLATION

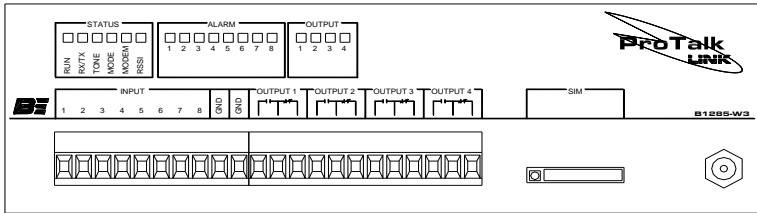

Figure 32 W3 Module Front Panel

The W3 module provides wireless callout capability through an embedded HSPA cell phone. In addition to communications functions, this module also has 8 digital inputs that can be independently programmed to operate as one of five different types:

- Standard digital
- Watchdog timer
- Interval timer
- Totalizer
- Accumulator

There are also 4 relay outputs that can be used for remote control; these relays are controlled by incoming DTMF codes.

For more advanced callout requirements, the module can be configured to send email and text messages containing the alarm information and can also receive text messages containing control codes. A limited amount of programming can also be done using a Touch-Tone set locally or by calling into the module.

Connectors

Refer to Figure 33 below for details of the connector pinouts.

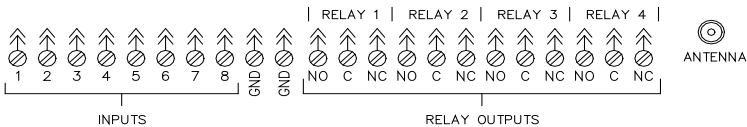

Figure 33 W3 Module Connections

Inputs

The eight digital inputs operate with a dry relay contact or open collector to ground as shown in Figure 34. In the open state the input is pulled high internally and in the ground state it is pulled to ground.

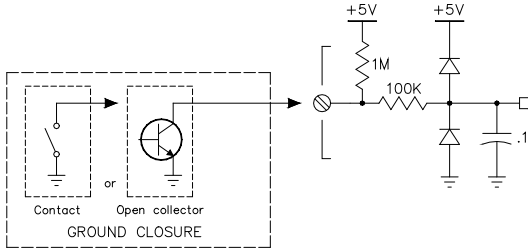

Figure 34 W3 Input Circuit

Relay Outputs

Each of the 4 relays can be configured during programming to provide remote control outputs that are operated by DTMF codes.

Indoor Antenna

Indoor Antenna Installation

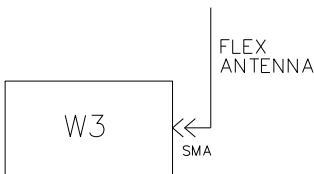

For the W3 Link module to successfully make cellular calls, there must be adequate signal strength at its antenna port. The flex antenna supplied with the module is suitable for installations where there is sufficient signal strength. This configuration is shown in Figure 35.

Figure 35 Indoor Antenna

Indicators

The indicators are grouped into 3 sections:

1) Status

Run

- Flashing Red during startup before a database is received from the main module
- Green during normal operations

RX/TX

- Green on receipt of valid message from the main module

- Yellow if the message from the main module has a checksum error. This indicator times out after 400 msec

Tone

- Green when a tone is being received
- Red when a tone is being transmitted
- Off when idle

Mode

- Green when connected to the home cellular network
- Yellow when connected to cellular network and roaming
- Red/Green flashing when ringing or call in progress
- Red when status is disconnected
- Off otherwise

Modem

- Green when modem is enabled
- Yellow when the modem has a data connection
- Red when disconnecting
- Off when disconnected

RSSI

- Flashing Red when RSSI is 0 (very poor)
- Red when RSSI is between 1 and 3 (poor)
- Yellow when RSSI is 4 or 5 (marginal)
- Green when RSSI is 6 or greater (good)
- Off for undetectable or unknown RSSI

2) Alarm

Eight, one for each input

- Flashing Red when the associated input is in the alarm state
- Red when the associated input is in the alarm state and has been acknowledged
- Green when active as an Interval or Accumulator
- Off when idle

3) Output

Four, one for each output

- Red when the relay is in the on state
- Yellow if the relay has failed
- Off otherwise

SIM Card Installation

The B1285-W3 utilizes an embedded HSPA cell phone module to make calls. To operate on a wireless network, a valid SIM card (Subscriber Identity Module) must be obtained from your carrier and installed in this module. The SIM cardholder is located on the front of the case. *It is important to observe proper electrostatic grounding precautions and to disconnect power prior to performing this procedure.*

What you'll need:

- Fine point object (eg. paper clip)
- Active SIM card

Installation Steps:

- Use a fine point object to depress the eject button.
- Remove the small black holder and place the SIM card in the holder taking note of the keyed pad.
- Return the holder with the SIM card through the slot in the front of the case.

12. W4 INSTALLATION

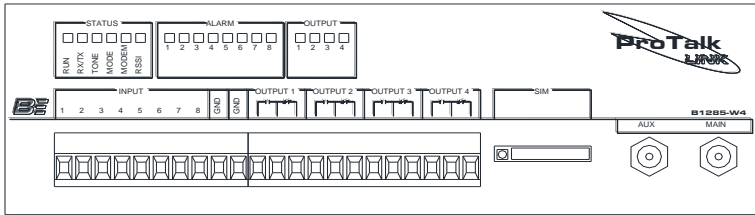

Figure 36 W4 Module Front Panel

The W4 module provides wireless callout capability through an embedded HSPA/LTE cell phone. In addition to communications functions, this module also has 8 digital inputs that can be independently programmed to operate as one of five different types:

- Standard digital
- Watchdog timer
- Interval timer
- Totalizer
- Accumulator

There are also 4 relay outputs that can be used for remote control; these relays are controlled by incoming DTMF codes.

For more advanced callout requirements, the module can be configured to send email and text messages containing the alarm information and can also receive text messages containing control codes. A limited amount of programming can also be done using a Touch-Tone set locally or by calling into the module.

Connectors

Refer to Figure 37 below for details of the connector pinouts

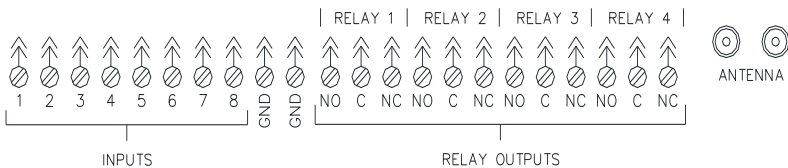

Figure 37 W4 Module Connections

Inputs

The eight digital inputs operate with a dry relay contact or open collector to ground as shown in Figure 34. In the open state the input is pulled high internally and in the ground state it is pulled to ground.

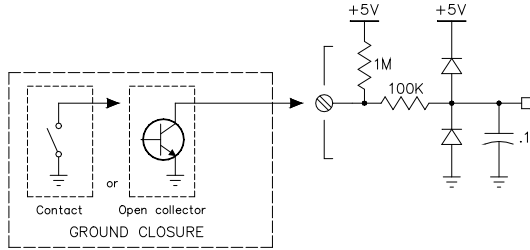

Figure 38 W4 Input Circuit

Relay Outputs

Each of the 4 relays can be configured during programming to provide remote control outputs that are operated by DTMF codes.

Indoor Antenna

Indoor Antenna Installation

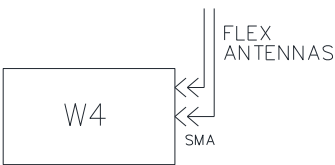

For the W4 Link module to successfully make cellular calls, there must be adequate signal strength at its antenna port. The flex antenna supplied with the module is suitable for installations where there is sufficient signal strength. This configuration is shown in Figure 39.

Figure 39 Indoor Antenna

A dipole antenna was included in the purchase of this product. This antenna is suitable for indoor use only and is limited in its range. The antenna should be connected to the ‘Main’ SMA connector. The ‘AUX’ port has been added to utilize future MIMO (multiple input multiple output) wireless technology. Please contact our sales office if your needs exceed the limits of this antenna, as we may be able to supply or recommend an appropriate substitute.

Indicators

The indicators are grouped into 3 sections:

1) Status

Run

- Flashing Red during startup before a database is received from the main module
- Green during normal operations

RX/TX

- Green on receipt of valid message from the main module
- Yellow if the message from the main module has a checksum error. This indicator times out after 400 msec

Tone

- Green when a tone is being received
- Red when a tone is being transmitted
- Off when idle

Mode

- Green when connected to the home cellular network
- Yellow when connected to cellular network and roaming
- Red/Green flashing when ringing or call in progress
- Red when status is disconnected
- Off otherwise

Modem

- Green when modem is enabled
- Yellow when the modem has a data connection
- Red when disconnecting
- Off when disconnected

RSSI

- Flashing Red when RSSI is 0 (very poor)
- Red when RSSI is between 1 and 3 (poor)
- Yellow when RSSI is 4 or 5 (marginal)
- Green when RSSI is 6 or greater (good)
- Off for undetectable or unknown RSSI

2) Alarm

Eight, one for each input

- Flashing Red when the associated input is in the alarm state
- Red when the associated input is in the alarm state and has been acknowledged
- Green when active as an Interval or Accumulator
- Off when idle

3) Output

Four, one for each output

- Red when the relay is in the on state
- Yellow if the relay has failed
- Off otherwise

SIM Card Installation

The B1285-W4 utilizes an embedded HSPA/LTE cell phone module to make calls. To operate on a wireless network, a valid SIM card (Subscriber Identity Module) must be obtained from your carrier and installed in this module. The SIM cardholder is located on the front of the case. *It is important to observe proper electrostatic grounding precautions and to disconnect power prior to performing this procedure.*

What you'll need:

- Fine point object (eg. paper clip)
- Active SIM card

Installation Steps:

- Use a fine point object to depress the eject button.
- Remove the small black holder and place the SIM card in the holder taking note of the keyed pad.
- Return the holder with the SIM card through the slot in the front of the case.

13. SPECIFICATIONS

13.1 Common module specifications

- Physical: 8.9" wide x 2.42" high x 4.32" deep
Steel, powder coated matte black
Mounting ears for panel installation
- Environmental: -40°C to + 60°C, 95% humidity, non-condensing
- Power: +10 VDC to +30 VDC
- Expander output: DB15 female (top of case to additional expander modules)
- Expander input: DB15 male (bottom of case to previous expander modules) not present on the M1 module
- Address Selector: 16 position rotary switch, access from the enclosure top
Not present on the M1 module

13.2 Detailed module specifications

13.2.1 M1 Module

This module is responsible for the operation of the Link system - consult the Programming section of this manual or the Help section of the LINK.EXE PC application for details on how the M1 module operates.

Digital Inputs: 2 total, dedicated as power fail and acknowledge inputs
 Input Levels: open / ground closure
 Impedance: 20k ohms
 Maximum +voltage: +30 VDC

Relay Outputs: 2 total, form C, 1A at 30 VDC

Program Ports: DB9

RS232, DTE 57,600 baud, 1 stop, no parity
 Connects to a PC for configuration programming,
 code updating and monitoring

USB

USB2

Same function as the DB9 port 1, disables the DB9
 when connected to a PC

Telset program port

RJ11

Connects to a DTMF telset for voice programming
 and limited configuration programming

Programmable Features

Site Name: This is a string of up to 16 characters usually representing the location of the Link system. The name is not used in voice announcements but is used for messages sent by email and in the Monitor operation that can be accessed by connecting to the main module with this application or through the internet if a PLC module is in the system.

Normally the Site Name will be the same or similar to the voice message for this point.

Battery Voltage: Internally connected to the primary DC power supply and can be programmed as an analog alarm.

Maximum signal full scale:	+30 VDC only
Decimal maximum:	+30.00 only
Decimal minimum:	0 only
Units:	Volts

- Power Failure:** Connected to external power fail signal and can be programmed as a digital alarm with ground closure operation.
- Relay Outputs:** Each of the two relays can be programmed to indicate one of these status conditions:
- New alarm exists
 - Any alarm exists
 - Acknowledge received
 - Error condition
- Any of the 8 groups can be included in the status for these states.
- These relays are not programmable as remote control outputs.
- Major Alarm:** This system alarm is the product of ORing all of the major alarms that can be set in each module. If enabled it produces the message 'Major alarm' when annunciated.
- Minor Alarm:** This system alarm is the product of ORing all of the minor alarms that can be set in each module. If enabled it produces the message 'Minor alarm' when annunciated.
- System Alarms:** Individual alarms can be set for:
- Vocabulary Error - checksum memory error detected
 - Database Error - checksum memory error detected
 - User Voice Error - checksum memory error detected
 - Clock Error - invalid time value
 - Expander Failure - any configured expander module is not responding

13.2.2 A1 Module

- Analog Inputs:** 8 current loop inputs:
- Impedance: 100 ohms floating
 - Maximum common mode voltage: +35 VDC
 - Operating range: 4-20 mA DC
- 8 voltage inputs:
- Single ended analog voltage referenced to ground
 - Impedance: 110k ohms to ground
 - Operating range: programmable for +5, +10 or +30 VDC full scale
 - Maximum input voltage: +35 VDC

Programmable features**Input**

Calibration:	Full scale (current inputs): 20 mA only Full scale (voltage inputs): +5, +10 or +30 VDC Decimal maximum +9999 Decimal minimum -9999 Hysteresis 1% to 25%
Delay Time:	Millisecond scale 10 to 65530 msec. in 10 msec. steps. Second scale 1 to 65535 seconds. Independent on and off delay settings
Major/Minor Alarm:	Current Loop is open Voltage Input is over range

13.2.3 D1 Module

Digital Inputs:	16 total Impedance: 250k ohms Maximum +voltage: +30 VDC Minimum +voltage: +5 VDC
Clear Inputs:	4 total, function as clear controls for digital inputs that are programmed as a totalizer or accumulator on inputs 1 to 4 respectively. Input format is the same as the setting for the associated digital input Impedance: 250k ohms Maximum +voltage: +30 VDC Minimum +voltage: +5 VDC

Programmable Features

Digital Inputs:	Can be standard digital, watchdog, pulse width, totalizer or accumulator types Input format: open / ground closure open / +voltage ground / +voltage
Major/Minor Alarm:	Input open with format set for ground / +voltage

13.2.4 P1 Module

Communications

Ports: RS232 (DTE) DB9
or RS485 (2 wire terminal block), selectable
Ethernet

Programmable Features

Major/Minor

Alarms: Each of these can be either a major or minor alarm:

- Ethernet link failure - when the link is lost due to a network disruption or disconnected cable.
- Email undeliverable - indicates that an email transmission did not reach the STMP server.

Communications

Ports: RS232 or RS485 (selectable)

- Stop bit: 1
- Parity: even, odd or none
- Checksum: CRC or BCC (A-B modes)
CRC (Modbus modes)
- Baud rate: 300
1200
2400
4800
9600
19200
38400
57600
115200

Ethernet:

- IP address: set by system administrator
- Subnet mask: set by system administrator
- Default gateway: set by system administrator
- Email server: set by system administrator

Block

Addressing: Data Type

Type defines the data type for the 16 registers in a block. For a PLC location Type can be bit, analog or bit array. For blocks that are occupied with other Link modules, Type will be defined by the hardware in that module.

Unit ID

Each block, consisting of 16 points, is assigned a Unit ID which is the address of the PLC. In slave mode all of the Unit ID values will be the same, changing this value in any block 0 will change all blocks. In master mode, each block can be assigned its own Unit ID to allow communications with multiple PLCs.

Start Address

Each block requires a value that represents the starting address of 16 sequential PLC registers. In master mode this address will be the register location in the PLC. In slave mode, Start is arbitrarily assigned starting with 1 in the first location in block 0 then in ascending order through the 32 blocks.

13.2.5 P2 Module**Communications**

Ports: RS232 (DTE) DB9
 RS485 (2 wire terminal block)
 Ethernet - Local PLC Network (10base-T)
 Ethernet - Remote Web/Email (10base-T)

Programmable Features**Major/Minor**

Alarms: Each of these can be either a major or minor alarm:

- Email/Web Network failure - when the link is lost due to a network disruption or disconnected cable.
- Email undeliverable - indicates that an email transmission did not reach the STMP server.
- PLC Network failure - when the link is lost due to a network disruption or disconnected cable.

Communications

Ports: RS232 and RS485

- Stop bit: 1
- Parity: even, odd or none
- Checksum: CRC or BCC (DF1 modes)
 CRC (Modbus modes)
- Baud rate: 300
 1200
 2400
 4800
 9600

19200
38400
57600
115200

PLC Ethernet Network:

IP address: set by system administrator
Subnet mask: set by system administrator
Default gateway: set by system administrator

Modbus/TCP

Port Number: set by system administrator

Email/Web Server Ethernet Network:

IP address: set by system administrator
Subnet mask: set by system administrator
Default gateway: set by system administrator
DNS server: set by system administrator

Web Server:

Username: set by system administrator
Password: set by system administrator
Port Number: set by system administrator

Email server:

Server Address: set by system administrator
Port Number: set by system administrator

Block Addressing:

Protocol

Each block, consisting of 16 points, is assigned a protocol and a PLC to communicate with. The protocol selected can be any of the always available Ethernet protocols or either of the previously configured protocols assigned to the RS232 or RS485 ports.

Data Type

Type defines the data type for the 16 registers in a block. For a PLC location Type can be bit, analog, or for some protocols, a bit array. For blocks that are located on a Link module, Type will be defined by the hardware in that module.

Unit ID / Station ID

Where the protocol requires, each block is assigned a Unit ID or Station ID which is the address of the PLC. In slave mode all of these values will be the same and is configured in the PLC Comm Settings section. In master mode, each block can be assigned its own value to allow communications with multiple PLCs.

Start Address

Each block requires a value that represents the starting address of 16 sequential PLC registers. In master mode this address will be the register location in the PLC. In slave mode, the Start Address is automatically assigned starting with 1 in the first location in block 0 then in ascending order through the 32 blocks.

Output Assembly and Data Offset

For the EtherNet/IP protocol, the remote PLC writes data to an Assembly in the P2 module. The alarms in a block can be mapped to one of these assemblies and the assemblies are sized to span several blocks. The Data Offset value indicates where in the assembly the block of alarms is located.

13.2.6 T1 module

Digital Inputs:	8 total, ground closure operation Internally pulled up to +5 VDC 1 M ohm input impedance Programmable as standard digital, watchdog, pulse width, totalizer or accumulator types
Relay Outputs:	4 total, form C, 2A at 30 VDC Programmable as on/off or timed Latching coils, can be programmed to maintain previous state on power-up
Telco port:	RJ11 Connects to telephone line
Radio port:	TX audio: 600 ohms, single ended, capacitively coupled adjustable -20 dBm to 0 dBm RX audio: 10K ohms, single ended, capacitively coupled adjustable -20 dBm to 0 dBm PTT: open collector, 25 VDC max, 100 mA max COS: 10K ohms, ground closure

Programmable Features**Major/Minor**

Alarms:	Each of these can be either a major or minor alarm: Relay Failure - when the contact position does not match the coil setting
---------	--

- No dial tone - when there is no dial tone because the telco line is not connected or the port has been damaged
- PTT Warmup: The interval between when the PTT signal is asserted to activate the radio transmitter and the beginning of the message.
Can be 0 to 65530 msec. in 10 msec. steps.
- COS Detect: The Carrier Operated Switch (COS) is a signal that is generated by the radio receiver to indicate that it is busy.
Disable - not used for busy channel detect
Busy Hi - high level when the receiver is active
Busy Lo - Low level when the receiver is active
- Audio Levels: Variable from 0 dBm to -20 dBm.
For the TX controls this setting will be the level that the audio signal for that type is transmitted at. For the RX setting it is the level of the signal coming from the receiver.
- | | |
|----------|-----------------------------|
| TX Tone | 2/5 Tone paging, alert tone |
| TX DTMF | DTMF signaling |
| TX Voice | Voice messages |
| Receive | All audio |
- Rings Before Answer: 1 to 9 or never
This sets the number of rings that must be detected before the line is answered

13.2.7 W1 Module

- Digital Inputs: 8 total, ground closure operation
Internally pulled up to +5 VDC
1 M ohm input impedance
Programmable as standard digital, watchdog, pulse width, totalizer or accumulator types
- Relay Outputs: 4 total, form C, 2A at 30 VDC
Programmable as on/off or timed
Latching coils, can be programmed to maintain previous state on power-up
- Antenna port: 50 ohms, SMA female

Programmable Features

- Major/Minor Alarms: Each of these can be either a major or minor alarm:

Relay Failure - when the contact position does not match the coil setting.

Roaming - indicates abnormal phone behavior since the Link is presumably installed at a fixed location.

Unknown Cell Status - failure to obtain network connection so there can be no callout actions.

Low RSSI - insufficient signal strength to reliably operate the cell phone.

APN server: Access Point Name server. Rogers access point to obtain an IP address and establish connection to the internet. For Rogers in Canada the default is "vpn.com".

APN user: Access Point Name user. For Rogers in Canada the default is "wapuser1".

APN password: Access Point Name password. For Rogers in Canada the default is "wap".

SMTP server: Rogers wireless email server.

APN SMTP server: Required to use the SMTP server.

Account address: This will appear in the "From:" portion of an outgoing email. It is the address where the outgoing email containing the current IP address of the wireless port is sent for a data transfer session.
example: From: your.name@yourcompany.com

13.2.8 W2 module

Digital Inputs: 8 total, ground closure operation
Internally pulled up to +5 VDC
1 M ohm input impedance
Programmable as standard digital, watchdog, pulse width, totalizer or accumulator types

Relay Outputs: 4 total, form C, 2A at 30 VDC
Programmable as on/off or timed
Latching coils, can be programmed to maintain previous state on power-up

Antenna port: 50 ohms, SMA female

Programmable Features

Major/Minor

Alarms: Each of these can be either a major or minor alarm:

Relay Failure - when the contact position does not match the coil setting

Roaming - indicates abnormal phone behavior since the Link is presumably installed at a fixed location

Low RSSI - insufficient signal strength to reliably operate the cell phone

13.2.9 W3 Module

- Digital Inputs: 8 total, ground closure operation
Internally pulled up to +5 VDC
1 M ohm input impedance
Programmable as standard digital, watchdog, pulse width, totalizer or accumulator types
- Relay Outputs: 4 total, form C, 2A at 30 VDC
Programmable as on/off or timed
Latching coils, can be programmed to maintain previous state on power-up
- Antenna port: 50 ohms, SMA female
- SIM Card: Mini-SIM 25.00mm (L) x 15.00mm (W) x 0.76mm (H)
Front panel accessible

Programmable Features

Major/Minor

- Alarms: Each of these can be either a major or minor alarm:
- Relay Failure - when the contact position does not match the coil setting.
 - Roaming - indicates abnormal phone behavior since the Link is presumably installed at a fixed location.
 - Unknown Cell Status - failure to obtain network connection so there can be no callout actions.
 - Low RSSI - insufficient signal strength to reliably operate the cell phone.
- Carrier: Wireless provider name. This edit control populates the following names with preset values, selecting 'custom settings', however, allows any value to be specified overwriting these defaults.
- Carrier APN: Access Point Name for your carrier. This service is used to obtain an IP address for a data connection to the internet. Each wireless carrier has a unique APN name

	that is used when sending emails or obtaining update files.
Email Server:	Name of a remote email server to route outgoing email messages through. Some wireless carriers have dedicated email servers but external ones, like gmail can also be specified.
Port:	The Port Number on the Email Server that accepts email messages. Unsecured emails use port 25; secured emails use 465 or 587 depending on the secure message protocol. Consult the email server for the appropriate value.
Username:	Your account on the Email server that allows you to send messages. Some servers, in an effort to prevent spam, will only permit messages to originate from an user that is authenticated by having an account.
Password:	Your authentication account password for the above Username.
Sender's Email Address:	This field will populate the "From:" portion of an outgoing email. example: From: <u>your.name@yourcompany.com</u>

13.2.10 W4 Module

Digital Inputs:	8 total, ground closure operation Internally pulled up to +5 VDC 1 M ohm input impedance Programmable as standard digital, watchdog, pulse width, totalizer or accumulator types
Relay Outputs:	4 total, form C, 2A at 30 VDC Programmable as on/off or timed Latching coils, can be programmed to maintain previous state on power-up
Antenna port:	50 ohms, SMA female
SIM Card:	Mini-SIM 25.00mm (L) x 15.00mm (W) x 0.76mm (H) Front panel accessible

Programmable Features

Major/Minor

Alarms: Each of these can be either a major or minor alarm:

Relay Failure - when the contact position does not match the coil setting.

Roaming - indicates abnormal phone behavior since the Link is presumably installed at a fixed location.

Unknown Cell Status - failure to obtain network connection so there can be no callout actions.

Low RSSI - insufficient signal strength to reliably operate the cell phone.

- Carrier: Wireless provider name. This edit control populates the following names with preset values, selecting 'custom settings', however, allows any value to be specified overwriting these defaults.
- Carrier APN: Access Point Name for your carrier. This service is used to obtain an IP address for a data connection to the internet. Each wireless carrier has a unique APN name that is used when sending emails or obtaining update files. For Verizon Wireless, this field is left blank as that information is obtained from the network.
- Email Server: Name of a remote email server to route outgoing email messages through. Some wireless carriers have dedicated email servers but external ones, like gmail can also be specified.
- Port: The Port Number on the Email Server that accepts email messages. Unsecured emails use port 25; secured emails use 465 or 587 depending on the secure message protocol. Consult the email server for the appropriate value.
- Username: Your account on the Email server that allows you to send messages. Some servers, in an effort to prevent spam, will only permit messages to originate from an user that is authenticated by having an account.
- Password: Your authentication account password for the above Username.
- Sender's Email Address: This field will populate the "From:" portion of an outgoing email.
example: From: your.name@yourcompany.com

13.3 Common alarm specifications

Alarm Name: Alarm name contains up to 16 characters to describe the alarm. The name is not used in voice announcements, but is used for messages sent by email, SMS text, in the Monitor operation (that can be accessed by connecting to the main module with this application), or through the internet if a PLC module is in the system. Normally the Alarm Name will be the same or similar to the voice message for this point.

Using Group: To enable the alarm it has to be put into one of the 8 groups. Note that the Group that the alarm is assigned to must also be enabled for alarm reporting.

DTMF TX Code: If one or more DTMF digits are entered in Alarm On Code, they will be transmitted when a SIGNAL command in a directory is encountered. A string of up to 7 digits is allowed.

Alarm Format: When Alarm Format is set for latched, the alarm condition will remain, even if the input state returns to normal and can only be cleared when it has been annunciated and acknowledged. In the case of an analog input, the first alarm condition that occurs is the one that is latched. This means that if a high alarm state is encountered, it will be latched and remain there even if the reading drops and goes into the low alarm state.

13.4 Detailed alarm specifications

13.4.1 Hardware digital alarm types

Function: Sets the type of functions that the input will perform and can be one of these 5 types:

- 1) Digital Input - standard digital alarm
- 2) Watchdog - alarms unless refreshed
 Watchdog Timer
 2 time scales are available for the watchdog timer
 Second scale, 66535 seconds maximum
 Minutes scale, 66535 minutes maximum
 Can be configured to restart the timer by either or both polarity changes at the input
- 3) Interval - measures the duration of an input state
 2 time scales are available for the interval timer
 Second scale, 66535 seconds maximum
 Minutes scale, 66535 minutes maximum
 Can be configured to measure either polarity at the input
- 4) Totalizer - counts input events
 5 counting scales are available to place the decimal point
 XXXXX.
 XXXX.Y
 XXX.YY
 XX.YYY
 X.YYYY
 Can be configured to count either or both polarity changes at the input, maximum count 65535
- 5) Accumulator - accumulates total time of input activity
 4 time scales are available
 Seconds, 66535 seconds maximum
 Minutes, 66535 minutes maximum
 .1 Hours, 6653.5 hours maximum
 Hours, 66535 hours maximum

*only digital and watchdog types generate alarms

Debounce On
 Time:

When the input level changes from the idle to alarm state, it must remain in that state for the interval set by the Debounce On time. If the state returns to idle before the debounce time has expired, no action takes place. Two time scales are available for the debounce timer.

Millisecond scale 10 to 65530 msec. in 10 msec. steps.
 Second scale 1 to 65535 seconds.
 Independent on and off delay settings for each input.

Debounce Off

Time: Working in reverse to the Debounce On Time, if the input is in alarm and goes to the idle state it must remain there for the Debounce Off time before it is considered to be idle.

Off = On: Sets the Debounce Off time to be equal to the On time

13.4.2 Hardware analog alarm types

Input

Calibration: To make an analog input usable, it needs to be calibrated by setting the correspondence between the input readings and the decimal values they represent, as well as entering the setpoints that will be used for generating alarms.

Maximum: The two values entered in the maximum setting controls are the highest output from the instrument and its corresponding decimal value. The actual values that can be entered here depend on which module that the analog input is in. Details on what is allowed for each module type are shown in the specification for that module.

Minimum: The two values in the minimum setting controls are the lowest output from the instrument and its corresponding decimal value.

Alarm

Setpoints: Set point values for high and low alarms are shown in bars. Set point values can be modified either by moving the slider or by entering the value in the Set box below the sliders. Set point values can have up to 4 digits plus a decimal point making the range between -9999 and 9999. When setpoints need to be annunciated for values greater than 9999, the Units settings can be used to express larger numbers. For the high Set point, there is an associated High Reset value that is determined by the Hysteresis setting. When the point has exceeded the high set point and has become an alarm, it must then drop below the High Reset level before it is considered to be in the normal state. Similarly, the value must be above the Low Reset value to return to normal from a low alarm state.

Hysteresis: 1% to 25%

Hysteresis is used to determine when the input reading returns to normal after it is in an alarm condition. The value shown here is a percentage of the decimal range (maximum - minimum). For the maximum set point the hysteresis value is subtracted from that set point and for the minimum set point it is added to that set point. Hysteresis is shown as a blue band extending from the set point. Changing the Hysteresis setting will automatically adjust the reset values.

Units: There are 3 unit controls that determine the descriptive phrase that is appended to the reading when it is annunciated. The first selection is a multiplier (e.g.: thousand or million); the second selection is a measurement unit (e.g.: degrees or PSI) and the third selection is a qualifier (e.g.: per second or per hour). The options for each selection are listed below:

Prefix	Unit	Suffix
NONE	NONE	NONE
THOUSAND	CUBIC METERS	PER DAY
MILLION	CUBIC YARDS	PER HOUR
MILLI	CUBIC FEET	PER MINUTE
CENTI	PSI	PER SECOND
KILO	POUNDS	
MEGA	METERS	
GIGA	RPM	
	GALLON	
	BARRELS	
	PARTS PER MILLION	
	VOLTS	
	WATTS	
	AMPS	
	DEGREES	
	FEET	
	GRAMS	
	INCHES	
	KPA	
	LITRES	

Delay On Time: This setting is equivalent to debouncing the transition between the normal and alarm states. When the value first exceeds a set point, either high or low, the Delay On Time is started and if the value remains outside of the set point for the time interval, it will become an

alarm. If the value drops within the set point before the timer has expired, the timer is cleared and no action occurs.

2 time scales are available for the delay timer.

Millisecond scale 10 to 65530 msec. in 10 msec. steps.

Second scale 1 to 65535 seconds.

Independent on and off delay settings.

Delay Off Time: This works in reverse of the Delay On Time where an analog that is in the alarm state must remain in the non-alarm region for the Off time before it is considered idle.

In this case the non-alarm region is defined by the Alarm Reset value.

Off = On: Sets the Delay Off time to be equal to the On time

13.4.3 Hardware relay outputs

For relays in certain modules, the controls shown below may not be changeable. Details on what settings can be changed are shown in the specification for each module.

Output Type: Sets whether the relay is On/Off or Timed.

Action On Power-Up: Determines whether the relay is left in the same state as when the power was removed or if it is reset.

On Code: The DTMF code that turns the relay on. Can be a string of 1 to 7 digits.

Off Code: The DTMF code that turns the relay off. Can be a string of 1 to 7 digits.

Interval: For a timed relay type this determines how long it will remain on after the On Code has been received. Two time scales are available:

Second scale, 1 to 65535 seconds.

Minute scale, 1 to 65535 minutes.

13.4.4 PLC digital alarm types

Function: Sets the type of functions that the input will perform and can be one of these 3 types:

1) Digital Input - standard digital alarm

2) Commwatch - alarms if communications with the PLC is lost

Slave Mode

Timeout: 1 – 65535 An alarm occurs if the time interval specified in Timeout is exceeded. The timer is restarted when a valid poll is received

Scale: 2 time scales are available, seconds or minutes

Master Mode

Poll Fail

Count: The number of failed poll attempts before a commwatch alarm is triggered

3) Coil Output - Allows a DTMF code to modify the status of a PLC coil

On Code: The DTMF code that sets the coil to 1. Can be a string of 1 to 7 digits.

Off Code: The DTMF code that sets the coil to 0. Can be a string of 1 to 7 digits.

13.4.5 PLC Analog alarm types

Function: Sets the type of functions that the input will perform and can be one of these 3 types:

1) Analog - Setup and calibration is the same as a hardware analog input except no debounce timers are provided. See section 10.2.3

2) Totalizer - Defines a point that can be used to announce the value of a PLC integer memory location. This point type will not generate an alarm condition

Decimal

Point: 5 scales are available to place the decimal point

XXXXX.

XXXX.Y

XXX.YY

XX.YYY

X.YYYY

Units: Totalizers use the same 3 unit controls that are provided for analog alarms to supply the descriptive phrase that is appended to the reading. See section 10.2.3

3) Commwatch - Analog commwatch alarms operate in a similar fashion to a digital commwatch. See section 10.2.5

14. HANDSET PROGRAMMING

The Link is capable of recording voice messages and limited programming using a safety approved Touch-Tone telephone, either locally through the programming port or remotely through a T1, W1, or W2 expander module. In place of the Enter key or carriage return that you would use to enter data from a keyboard, the Link interprets the digits ****** as the Enter command. Each entry consists of one or more digits followed by the ****** digits. Ensure that no more than one second separates the two ***** digits.

To begin a local programming session, lift the handset to your ear. For a remote session, call the Link system from your telephone set by calling the landline number that the T1 module is connected to or the cell phone number the W1, W2 or W3 module is using. Handset programming is always available locally; access for remote programming depends on the Security Level setting:

- Level 1: The call will be answered with a message containing the Site ID, any Groups that have alarms, followed by the prompt "Enter Command Code". An Access Code is not required.
- Level 2: The call will be answered with a message containing only the Site ID. To advance any further, the caller must enter the Access Code within 10 seconds.
- Level 3: An incoming call results in the Link coming off-hook with no announcement. To advance any further, the caller must enter the Access Code within 10 seconds.

The Link has stored voice prompts to guide you through the programming session. The first message you will hear is "Enter Command Code". At this time you can interrogate or acknowledge alarms and send control codes to output points. In the absence of a control code with the Security Level set to 1, the Link will automatically advance to the programming section and speak "Enter Program Code".

Programming Summary

The codes used in the main programming menu are given as a summary below.

- 1 * * Voices (page 66)
- 2 * * Directories (page 67)
- 3 * * Hardware Configuration (page 69)
- 5 * * General Configuration (page 70)
- 6 * * Group Configuration (page 72)
- 8 * * Reset Database (page 74)
- 9 * * Module Status (page 75)
- 0 * * Wireless Module Programming (page 76)
- 9 9 * * Local Handset Callout (page 78)
- * * * Query Version (page 79)

1 * * Voices

Link: "Enter Voice Code"

You: **0 * *** Playback or record voices for Site Name, then
Groups 1 to 8 then Block 0

1 * * Playback or record voices for Block 1

2 * * Playback or record voices for Block 2

• • •

3 1 * * Playback or record voices for Block 31

9 9 * * Erase all voices

* * Exit to Main Menu

*** *** Exit to Main Menu

Playback or Record Voices

Link: "Site is" "*Ajax Compressor Station*"

or "Block 1 {input, output, register, coil}" 1 is
"*Low Temperature*"

You: **2 * *** Record new voice

*** *** Accept current recording and advance to next
voice

* * Exit to voice menu

Recording:

Link: "beep"

You: "*Acme Lift Station*" (Recording stops with silence)

Link: "Site is" "*Acme Lift Station*"

Erase All Voices:

Link: "Enter Empty Code"

You: **# 3 1 * ***

Link: "Voices are empty"

2 Directories**

Link: "Enter Directory"

You: **1**** Directory 1
2** Directory 2
 ● ● ●
32** Directory 32
#** Exit to Main Menu
****** Exit to Main Menu

Directory Line

Refer to the command list that follows for the available directory entries.

Link: "Directory 1 Line 1 is DIAL 2559544 VOICE"

You: **2**** Edit current line
3** Erase current line
4** Insert line
****** Next line
#** Exit to Directory Menu

Edit current line

Link: "beep"

You: **#01234567 #8****
 (new line is DIAL 1234567 VOICE)

Insert new line

Link: "beep"

You: **#1 #8****
 (new line is RADIO VOICE)

Directory Commands

Directory programming requires you to enter a sequence of digits that corresponds to a directory line in the PC programming. All of the commands that would appear on that line have to be entered with one string ending in **(*)**. Each command consists of a **(#)** digit followed by the digit representing the command followed by digits representing the value (if needed). The list below shows the sequence of digits used to enter the commands and values; the value portion is shown as a single **(X)** and will vary depending on the command it is following.

- (#0X***)** DIAL **(X)** is the telephone number
- (#1***)** RADIO
- (#2X***)** WAIT **(X)** is the time in seconds, 1 to 255
- (#3***)** ALERT
- (#4X***)** 2 TONE **(X)** is the paging frequencies with an assumed decimal before the last digit with a **(*)** digit separating them.
(12345*6789) will give the A/B paging tones 1234.5/678.9
- (#5X***)** 5 TONE **(X)** is the 5 tone paging code with a **(*)** digit used to separate the preamble from the code. **(1*23456)** will give the code 23456 with preamble.
- (#6***)** SIGNAL Sends the DTMF Tx code for the alarm.
- (#7X***)** DTMF **(X)** is the string of DTMF digits
- (#8***)** VOICE
- (#9***)** ANSWER
- (X***)** DIAL **(X)** is the telephone number. Special case where entering only digits automatically inserts the DIAL command followed by the VOICE command.

Email and AutoAck commands are not available through handset programming

3 Hardware Configuration**

Link: "Enter Module Address"

You: **0**** Address 0 (Main) Note: The switch uses the
1** Address 1 letters A to F to represent
 ● ● ● the numbers 10 to 15
15** Address 15
#** Exit to Main Menu
****** Next module

Address 1

Link: "Module Zero is M1"

You: **#**** Exit to Hardware Configuration
****** Exit to Hardware Configuration

Modules can no longer be added or edited through telset programming.

5** General Configuration

Link: "Acknowledge Timer is . . ."

You: **X**** Enter new value (0 = off, 1 = 30 min, 2 = 60 min,
3 = 120 min, 4 = 120min)

#** Exit to Main Menu

****** Next setting

Link: "Relay voices are . . ."

You: **X**** Enter new value (0 = off, 1 = on)

#** Exit to Main Menu

****** Next setting

Link: "Security Level is . . ."

You: **X**** Enter new value (1, 2 or 3)

#** Exit to Main Menu

****** Next setting

Link: "Access Code is . . ."

You: **X**** Enter a new DTMF code

#** Exit to Main Menu

****** Next setting

Link: "Shift Count is . . ."

You: **X**** Enter new value (1 to 8)

#** Exit to Main Menu

****** Next setting

Link: "Shift Code is . . ."

You: **X**** Enter a new DTMF code

#** Exit to Main Menu

****** Next setting

Link: "Auto Mode Enable is . . ."

You: **X**** Enter new value (0 = off, 1 = on)

#** Exit to Main Menu

****** Next setting

Link: "Primary Phone Address is . . ."

You: **X**** Enter new value (1 to 15 - module address,
0 = none)

#** Exit to Main Menu

****** Next setting

Link: "Backup Phone Address is . . ."

You: **X**** Enter new value (1 to 15 - module address,
0 = none)

#** Exit to Main Menu

****** Next setting

Link: "Primary Phone Modem Code is . . ."

You: Enter new DTMF code
 Exit to Main Menu
 Next setting

Link: "Backup Phone Modem Code is . . ."

You: Enter new DTMF code
 Exit to Main Menu
 Next setting

6 Group Configuration**

Link: "Enter Group Number"

You: **1**** Group 1

2** Group 2

•••

8** Group 8

#** Exit to Main Menu

****** Exit to Main Menu

Link: "Group One is ..."

You: **X**** Enter new value (0 = off, 1 = on)

#** Exit to Main Menu

****** Next setting

Link: "Acknowledge Code is ..."

You: **X**** Enter a new DTMF code

#** Exit to Main Menu

****** Next setting

Link: "Interrogate Code is ..."

You: **X**** Enter a new DTMF code

#** Exit to Main Menu

****** Next setting

Link: "Short Timer is ..."

You: **X**** Enter new value (1 to 255 min.)

#** Exit to Main Menu

****** Next setting

Link: "Short Cycles is ..."

You: **X**** Enter new value (0 to 9)

#** Exit to Main Menu

****** Next setting

Link: "Long Timer is ..."

You: **X**** Enter new value (1 to 255 min.)

#** Exit to Main Menu

****** Next setting

Link: "Acknowledge Request is ..."

You: **X**** Enter new value (0 = off, 1 = on)

#** Exit to Main Menu

****** Next setting

Link: "Automatic Acknowledge is ..."

You: **X**** Enter new value (0 = off, 1 = on)

#** Exit to Main Menu

****** Next setting

Link: "On Shift One Use Directory . . ."

You: Enter new value (1 to 32)

Exit to Main Menu

Next setting

••• repeats for the number set in Shift Count

Link: "On Shift Eight Use Directory . . ."

You: Enter new value (1 to 32)

Exit to Main Menu

Exit to Main Menu

8 * * Reset Database

Link: "Enter Empty Code"

You: #31**

Link: "Program is Empty"

9 Module Status**

Link: "Enter Module Address"

You: **0**** Address 0 (Main)

1** Address 1

•••

15** Address 15

#** Exit to Main Menu

****** Next module

Note: The switch uses the letters A to F to represent the numbers 10 to 15

Address 1

Link: "Module One is {module type or empty}"

Status (if available)

Link: " Signal Strength is . . ."

Module	Status
M1	none
A1	none
D1	none
P1	none
P2	none
T1	none
W1	Signal Strength (0 to 15; 3=poor, 6=good)
W2	Signal Strength (0 to 15; 3=poor, 6=good)
W3	Signal Strength (0 to 15; 3=poor, 6=good)
W4	Signal Strength (0 to 15; 3=poor, 6=good)

0 * * Wireless Module Programming

The W1 module is a GSM based module that is configured through a removable SIM module. This program code will only announce the Mobile Number that is assigned to the installed SIM module.

The W2 module is a CDMA based module that is pre-configured at the factory except for the assigned Mobile Number. This program code will allow reading the ESN from the device and then writing the Mobile Number to it as assigned it by the carrier.

The W3 module is an HSPA based module that is configured through a removable SIM module. This program code will only announce the Mobile Number that is assigned to the installed SIM module.

The first device programmed will be the one assigned as the PRIMARY PHONE device (see General Configuration). After programming this device, an attempt will be made to program the BACKUP PHONE device. If this is the same as the PRIMARY PHONE, the programming will exit. If neither devices are wireless modules, the Link will announce an error.

Where the PRIMARY and BACKUP PHONE devices are not wireless modules

Link: "Module Access Error"

For a W1 Module

Link: "Module W1 Mobile Number is . . ."

You: * * Advance to next wireless module

For a W2 Module

Link: " Module W2 ESN is . . ."

You: * * Advance to MIN programming

* * Exit to Main Menu

For a W3 Module

Link: " Module W3 Mobile Number is . . ."

You: * * Advance to the next wireless module

* * Exit to Main Menu

Link: "Mobile number is . . ."

You: X * * Enter a new number.

* * Exit to Main Menu

* * Advance to the next wireless module

For a W4 Module

Link: " Module W4 Mobile Number is . . ."

You: * * Advance to the next wireless module
* * Exit to Main Menu

99 Local Handset Callout**

Link: "beep"

You: (X)(*)(*)

Enter the phone number you want to call

If the system has two callout modules (T1, W1, W2, W3 and W4) the call will be placed through the one that is set as primary. Hang-up to end the call.

* * * Query Version

Link: "Enter Module Address . . ."

You: **X*** * Enter the module address (0 to 15)

You: **#*** * Exit to Main Menu

You: ****** Exit to Main Menu

Link: "Module M0 is . . ." (speaks serial number)

You: **#*** * Exit to Query Version

You: ****** Next

Link: "Hardware version is . . ."

You: **#*** * Exit to Query Version

You: ****** Next

Link: "Firmware version is . . ."

You: **#*** * Exit to Query Version

You: ****** Next

Link: "Options are . . ."

You: **#*** * Exit to Query Version

You: ****** Exit to Query Version

For a B1285W4 Module

Link: "Module W4 Mobile Number is..."

You: ****** Advance to the next wireless module

You: **#*** * Exit to Main Menu

15. WARRANTY STATEMENT

Barnett Engineering Ltd. warrants that all equipment supplied shall be free from defects in material or workmanship at the time of delivery. Such warranty shall extend from the time of delivery for a period of one year. Buyer must provide written notice to Barnett Engineering Ltd. within this prescribed warranty period of any defect. If the defect is not the result of improper usage, service, maintenance, or installation and equipment has not been otherwise damaged or modified after delivery, Barnett Engineering Ltd. shall either replace or repair the defective part or parts of equipment or replace the equipment or refund the purchase price at Barnett Engineering Ltd.'s option after return of such equipment by buyer to Barnett Engineering Ltd.

Shipment to Barnett Engineering Ltd.'s facility shall be borne on account of buyer.

(1) Consequential Damages: Barnett Engineering Ltd. shall not be liable for any incidental or consequential damages incurred as a result of any defect in any equipment sold hereunder and Barnett Engineering Ltd.'s liability is specifically limited to its obligation described herein to repair or replace a defective part or parts covered by this warranty.

(2) Exclusive Warranty: The warranty set forth herein is the only warranty, oral or written, made by Barnett Engineering Ltd. and is in lieu of and replaces all other warranties, expressed or implied, including the warranty of merchantability and the warranty of fitness for particular purpose.

16. NOTICES

CSA Certification

The ProTalk Link product has 60950-1 safety certification for Canada and USA.

Compliance

This Class A digital apparatus complies with Canadian ICES-003. This device complies with part 15 of the FCC Rules. Operation is subject to the following two conditions:

- (1) this device may not cause harmful interference, and
- (2) this device must accept any interference received, including interference that may cause undesired operation.

Warning

This equipment generates, uses and can radiate radio frequency energy and, if not installed and used in accordance with the instructions manual, may cause interference to radio communications.

Operation of this equipment in a residential area is likely to cause interference. Should this occur, the user (at his own expense) will be required to apply whatever measures necessary to correct the interference.